

K9 Illuminated Pushbutton Switch

SMT momentary switch

50% reduction in installation cost.

- Depth behind panel : Only 12 mm
- LED Full-Face, Dual-Color
- Terminal : Surface Mount Terminal
- Selectable with or without Click feeling.

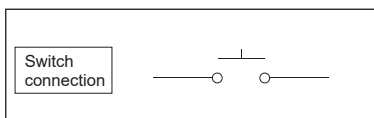
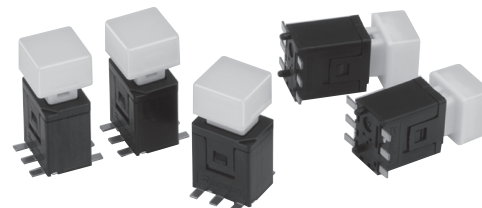

CHARACTERISTICS

Button size	Square : □9 mm
Contact Material	Gold-Plated
Rating (Resistive Load)	DC 24 V 20 mA
Insulation Resistance	More than 100 MΩ at DC 500 V
Dielectric Strength	AC 1000 V RMS between N and NO terminal AC 1500 V RMS between terminals and ground 50/60 Hz for 60 sec. at normal ambient temperature and humidity
Contact Resistance	Less than 200 mΩ at DC 6 V 0.1 A
Vibration Resistance	300 m/s max. (Malfunction) 500 m/s max. (Destruction)
Mechanical Life	Momentary More than 300,000 operations
Electrical Life (Resistive Load)	More than 300,000 operations
Operating Force	2.0 N max.
Total Travel	2.0 mm max.
Weight	3.6 g
Ambient Operating Temperature	(No Condensation)
Ambient Operating Humidity	85%RH MAX. (No Freeze)
Ambient Storage Temperature, Humidity	Indoors at a temperature of 25°C or less and relative humidity of 50% or less

https://www.sunmulon.co.jp/english/products/switch_e/k9.html



◇Dimensions : page K9-3

◇LED specifications : page K9-7~8

◇Ordering code : page K9-4~5

◇Terminals / PCB hole cutout : page K9-9

◇Internal connection arrangements : page K9-6

SPECIFICATIONS

Button size	Square	9 mm
Illumination type	Full-Face	A
	Dual-Color	A
Contact	SPST	A
Terminal	SMT	A
RoHS (10 Substances)	Conform to standards	

A : Applicable

CONTACT RATINGS

Rating	DC 24V 20 mA (Resistive load)
--------	-------------------------------

STRUCTURE

LIGHT CARTRIDGE

BUTTON

LED UNIT

HOUSING



ILLUMINATION TYPES

LED color symbol		7	Red	8	Green	9	Yellow	18	Super Green
※ Yellow (9) is actually "ORANGE Yellow" not Lemon Yellow.									
Full-Face		7	8	9					
Dual-Color		7·8	7·18						

DIMENSIONS

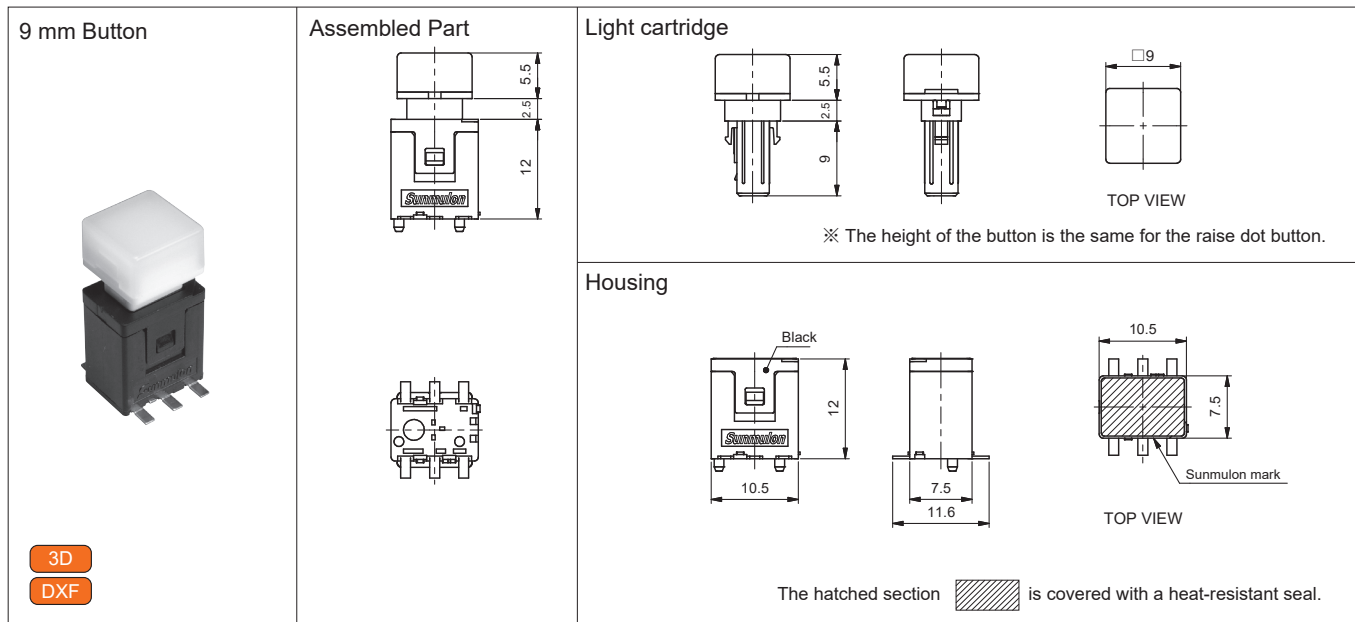

3D, DXF data download site : <https://www.sunmulon.co.jp/download/>

Tolerance : $\pm 0.4\text{mm}$

ORDERING CODE 【Full-Color】

LIGHT CARTRIDGE

K9 - 9 [] [] [] X

● **BUTTON SIZE**

9	9 mm Square
---	-------------

● **BUTTON SHAPE**

S	Flat
X	Without button

● **FILTER COLOR**

X	Without filter
---	----------------

● **BUTTON COLOR**

M	Milk-White
X	Without button

● **LED COLOR**

7	Red	
8	Green	
9	Yellow	※1)
X	Without LED	

For protecting LED, use external protective resistor.

● **NOTES**

※1) The color of "Yellow" for LED (9) is actually "Orange Yellow" not Lemon Yellow.

HOUSING

K9 [] - K M

● **CIRCUIT CHARACTERISTIC AND OPERATIONAL FEEL**

M	Momentary, with click feel
S	Momentary, without click feel

● **TERMINAL**

M	Surface-mounted terminal
---	--------------------------

● **HOUSING COLOR**

K	Black
---	-------

◇Dimensions : page K9-3 ◇Internal connection arrangements : page K9-6 ◇LED Specifications : page K9-7
 ◇Terminals / PCB hole cutout : page K9-9

ORDERING CODE [Dual-Color]

LIGHT CARTRIDGE

K9 - 9 **X**

● **BUTTON SIZE**

9	9 mm Square
---	-------------

● **BUTTON SHAPE**

S	Flat
X	Without button

● **FILTER COLOR**

X	Without filter
---	----------------

● **BUTTON COLOR**

M	Milk-white
X	Without button

● **LED COLOR**

78	Dual-color (Red / Green)
718	Dual-Color (Red / Super Green)

For protecting LED, use external protective resistor.

HOUSING

K9 - **K M**

● **CIRCUIT CHARACTERISTIC AND OPERATIONAL FEEL**

M	Momentary, with click feel
S	Momentary, without click feel

● **TERMINAL**

M	Surface-mounted terminal
---	--------------------------

● **HOUSING COLOR**

K	Black
---	-------

◇Dimensions : page K9-3 ◇Internal connection arrangements : page K9-6 ◇LED Specifications : page K9-8
 ◇Terminals / PCB hole cutout : page K9-9

REPLACEMENT PARTS

● BUTTON

	Milk-White
9 mm Square	K9-4707-LM

INTERNAL CONNECTION ARRANGEMENT

● Full-Face

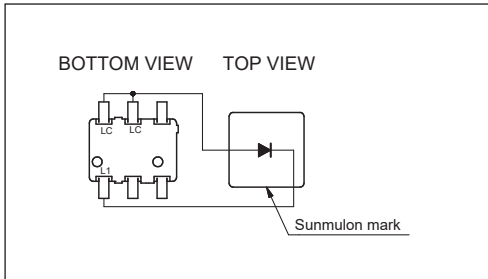

● Dual-Color

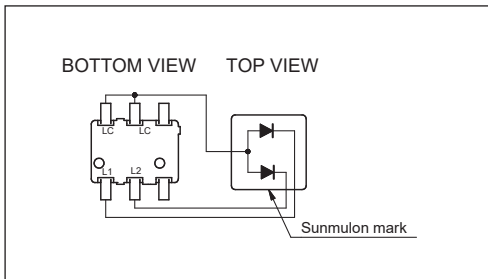

● Dual-Color combination

Terminals	LED Color	
LC-L1	Red	Red
LC-L2	Green	Super Green

LED SPECIFICATIONS [Full-Face]

Item	Color	Red	Green	Yellow
	Max. Forward Current I_{FM}	(mA)	25	20
Power Dissipation	(mW)	60	48	60
DC Reverse Voltage V_R	(V)	5	5	5
Forward Voltage V_F (Typ.) ^{**}	(V)	1.9	2.1	1.9
Dominant wavelength λ_d ^{**}	(nm)	626	572	595
Forward current under the above conditions ^{**}	(mA)	20	20	20
Pulse Lighting	Pulse Width PW	400 (μs)		
	Duty Ratio DR	10 ⁻¹		
	Allowable forward current I_{FP}	92 (mA)		

● Wiring Diagram

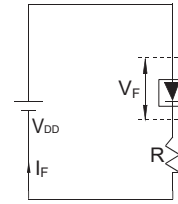

Refer to the following formula to calculate external resistance values.

$$R = \frac{V_{DD} - V_F}{I_F}$$

V_{DD} : Supply Voltage
 V_F : Forward Voltage
 I_F : Forward Current

● Maximum forward current — Ambient temperature

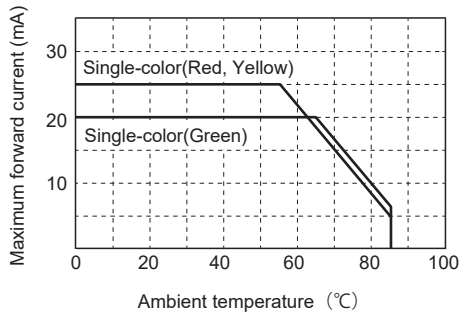

● Reference external resistor

Since LED protection resistors are not built-in, connect resistors in series referring to the table below.

Ta=25°C

Voltage \ Color	Red	Green	Yellow
DC 5V	910Ω 1/16W	390Ω 1/16W	470Ω 1/16W
DC 12V	3kΩ 1/8W	1.3kΩ 1/4W	1.6kΩ 1/4W
DC 24V	6.8kΩ 1/4W	2.7kΩ 1/2W	3.6kΩ 1/2W
Reference forward current (mA)	4	8	6

For resistance value calculation

<https://www.sunmulon.co.jp/english/products/led.html>

The resistance value can be calculated just by entering the items.

LED SPECIFICATIONS [Dual-Color]

Item	Color	Red • Green (78)			Red • Super Green (718)	
		Red	Green		Red	Super Green
			□12	□15		
Max. Forward Current I_{FM}	(mA)	25 (17)	20 (14)	20 (14)	20 (16)	10 (8)
Power Dissipation	(mW)	60	48	48	48	38
DC Reverse Voltage V_R	(V)	5	5	10	5	5
Forward Voltage V_F (Standard value)※	(V)	1.9	2.1	4.2	1.8	3.4
Dominant wavelength λ_d ※	(nm)	626	572	572	626	525
Forward current under the above conditions※	(mA)	20	20	20	10	10
Maximum Forward Current		Figure 1			Figure 2	
Pulse Lighting	Pulse Width PW	400			400	15
	Duty Ratio DR	10^{-1}			10^{-1}	10^{-1}
	Allowable forward current I_{FP}	92			92	50

※ In case of Simultaneous lighting, please follow the figures in ().

● Wiring Diagram

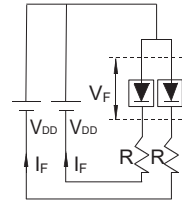

Refer to the following formula to calculate external resistance values.

$$R = \frac{V_{DD} - V_F}{I_F}$$

V_{DD} : Supply Voltage
 V_F : Forward Voltage
 I_F : Forward Current

● Maximum forward current — Ambient temperature

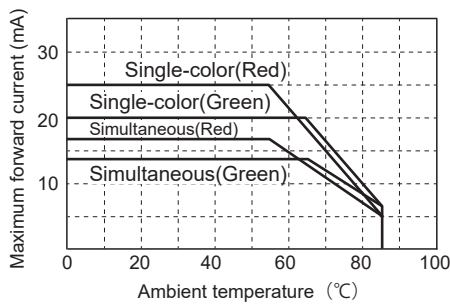

(Figure 2)

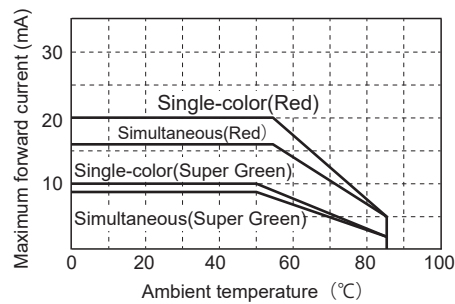

(Figure 3)

● Reference external resistor

Since LED protection resistors are not built-in, connect resistors in series referring to the table below.

$T_a = 25^\circ\text{C}$

Voltage	Red • Green (78)		Red • Super Green (718)	
	Red	Green	Red	Super Green
DC 5V	910Ω 1/16W	390Ω 1/16W	750Ω 1/16W	1.2kΩ 1/16W
DC 12V	3kΩ 1/8W	1.3kΩ 1/4W	2.4kΩ 1/8W	4.7kΩ 1/16W
DC 24V	6.8kΩ 1/4W	2.7kΩ 1/2W	5.1kΩ 1/4W	11kΩ 1/8W
Reference forward current (mA)	4	8	4	2

For resistance value calculation

<https://www.sunmulon.co.jp/english/products/led.html>

The resistance value can be calculated just by entering the items.

TERMINALS / PCB HOLE CUTOUT

● TERMINALS LAYOUT (BOTTOM VIEW)

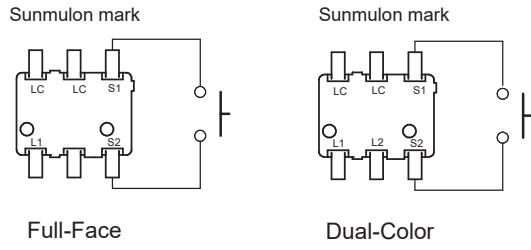

● PCB hole cutout (TOP VIEW)

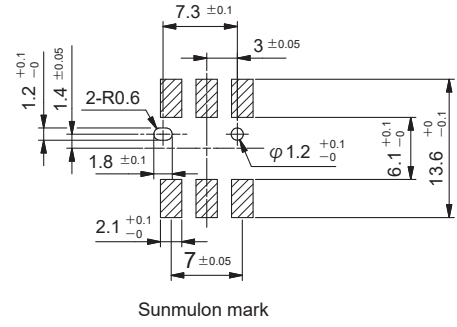

TERMINAL SHAPE

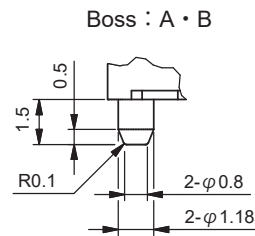
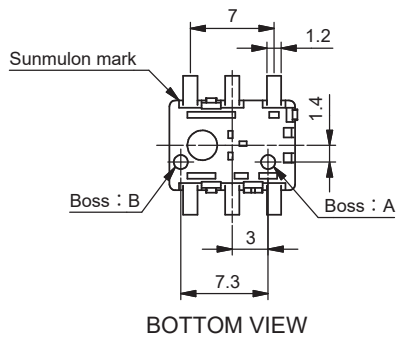

Tolerance : ± 0.4mm

SOLDERING SPECIFICATIONS

● Soldering

- (1) Conduct preliminary testing for confirming the soldering conditions.
Switches could be deformed by heat depending on the pattern and land on the PCB.
- (2) The number of soldering is no more than twice, including corrective re-soldering.
When soldering repeatedly, wait at least five minutes between the first and second soldering until the work cools to room temperature.
Continuous heating can result in deformity of outer contours or deterioration.

● Recommended conditions for reflow soldering (When attaching single terminal)

Please set a reflow furnace referring to the temperature profile example shown below for the terminal temperature.
Deformity could result due to the heat if the product temperature exceeds 260°C, therefore ensure that the temperature on the product surface remains below 260°C.

Pre-heating : 150°C to 180°C
60 to 120 sec
Reflow : 220°C or above
within 30 to 60 sec
Solder type : Sn 96.5
Ag 3
Cu 0.5
※A30C5 (JIS indication)

※Consult with us if you wish to attach parts continuously or in high density.

[Temperature profile example when lead-free solder is used]

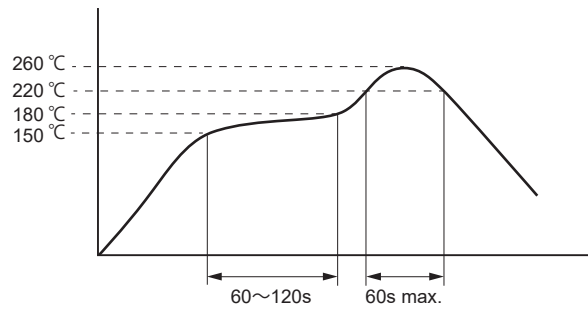

● Manual soldering

- (1) Soldering temperature : 350°C or less at tip of soldering iron.
- (2) Soldering time : within 3 sec

● Cleaning

The switches are not washable.
Washing may cause flux and foreign matter on the PCB to get inside the switch along with cleaning fluid, and could cause failure.

● PCB

- (1) When recommend confirming thickness of the PCB, pattern on the PCB and land prior to volume production.
- (2) Handle the PCB carefully when dividing the PCB could get inside the switches.
Avoid piling assembled PCB.

SURFACE MOUNTING PROCESS

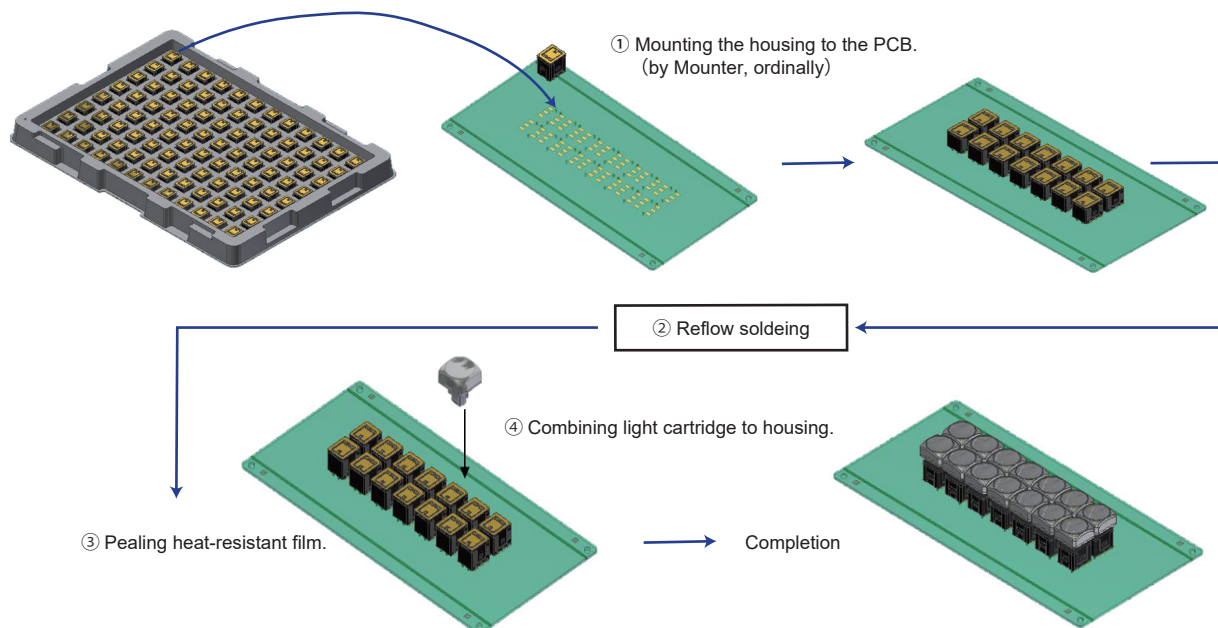

Tolerance : ± 0.4mm

PACKAGING SPECIFICATIONS

- The housing of K9 series switches is delivered in a tray. Tray specifications are as shown below.

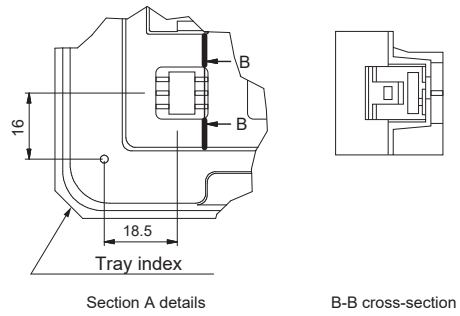
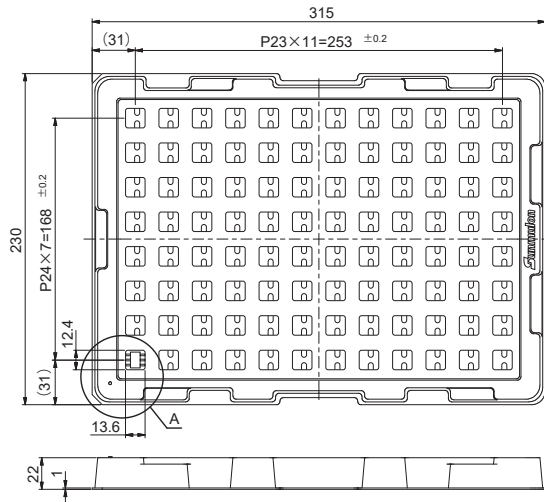

Tray	Part no.	K2-4704
------	----------	---------

The light cartridge is always delivered in a product box.

ASSEMBLY

- Mounting the light cartridge

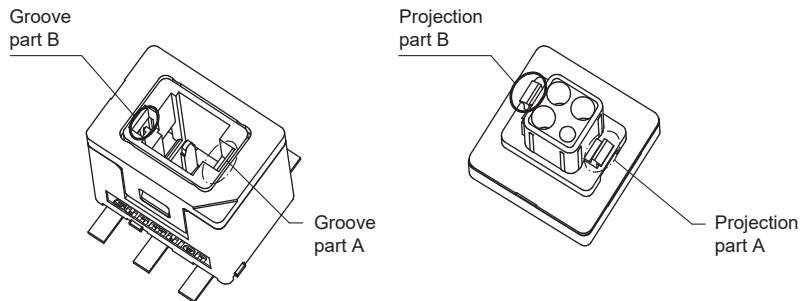

To combine the light cartridge with the housing, remove the seal attached to the housing. There is a proper direction for combining the light cartridge with the housing. As shown in the above diagram, insert the light cartridge by aligning the projection part A with the groove part A, and the projection part B with the groove part B.

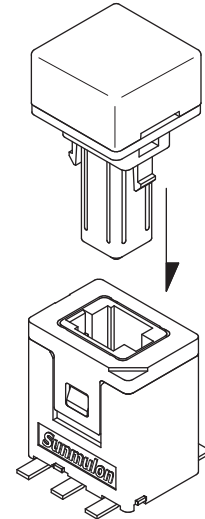

Tolerance : $\pm 0.4\text{mm}$

PRECAUTIONS FOR CORRECT USE

● Handling of switches

(1) Usage environment

Prior to setting the product in the environment for actual usage, check that no corrosive or other gas is emitted from component parts in the vicinity.

Avoid using in atmospheres containing sulfidizing gas (H₂S, SO₂), ammonia gas (NH₃), nitrate gas (NO₂), chlorine gas (Cl₂) or other corrosive gases, or under high temperature or humidity.

(2) Contact errors could result if silicon is present in the vicinity of the switch.

Remove the source of silicon if silicon oil, silicon filler, silicon wire or other silicon products are present around the switch.

(3) Dust-prevention measures

Avoid using the switches in places where dust is generated.

(4) Waterproofing and drip-proofing

The switches are not waterproof or drip-proof. Avoid installing or using them in places where they might be splashed with liquids.

(5) Automatic mounting

The switches can be mounted automatically on baseboards, but this may not be possible with some types of mounting machines.

We recommend checking beforehand when using the product this way.

(6) Strength of terminals

Note that if a terminal is bent or twisted, its strength declines and the terminal could break.

● Matters for caution when storing

(1) Storage environment

When storing the product, please take full consideration that the atmosphere, humidity and other storage conditions could affect the ease of soldering of terminals and packaging functions.

-Packaging material is expected to age more rapidly under high temperatures and humidity. We recommend storing the products indoors at temperatures up to 25°C and relative humidity up to 50%.

-Avoid storing the products in an environment with sulfidizing or other corrosive gases.

-Avoid direct sunlight and dust.

(2) Storage conditions

Store the products in the packaging.

Use products promptly after opening the packaging, and store the remaining products in an area free of gas, humidity and other factors which might affect performance.

Handle the products carefully to prevent damage to terminals from deforming.

Tolerance : ± 0.4mm

As of June 2022

Safety Precautions for All Illuminated Pushbutton Switches

1. Notes on contents of Catalogs

- (1) Rated values, performance values, and specification values of Sunmulon products listed in this catalog are values acquired under respective conditions in independent testing, and do not guarantee values gained in combined conditions.
- (2) The ambient operating temperature(humidity) is guaranteed by evaluation based on characteristics, and does not guarantee continuous use for a long period of time near the upper or lower limit of the ambient operating temperature(humidity) or permanent use at that temperature(humidity).
- (3) Reference data and reference values listed in catalogs are for reference purposes only, and do not guarantee that the product will always operate appropriately in that range.
- (4) The specifications / appearance and accessories of Sunmulon products listed in catalogs are subject to change or termination of sales without notice, for improvement or other reasons.
- (5) The content of catalogs is subject to change without notice.

2. Note on applications

- (1) If using Sunmulon products in combination with other products, confirm the following suitability by yourself. Sunmulon shall provide no guarantees regarding the combination suitability.
 - (a) Regulations, standards, or laws to which your machinery, equipment, etc. must conform
 - (b) Functionality and safety of your machinery and equipment
- (2) Wiring and installation that ensures the Sunmulon product used in your system, machine, device, or the like can perform and function according to its specifications.
- (3) When using Sunmulon products, be cautious when implementing the following.
 - (a) Use of Sunmulon products with sufficient allowance for rating and performance.
 - (b) Safety design, including redundant design and malfunction prevention design that prevents other danger and damage even in the event that Sunmulon product fails.
- (4) Sunmulon products are designed and manufactured as general-purpose products for general industrial products. They are not intended for use in the following applications, and in the event that you use Sunmulon product for these applications, unless otherwise agreed upon between you and Sunmulon, Sunmulon shall provide no guarantees whatsoever regarding Sunmulon products.
 - (a) Safety devices intended for human body protection
 - (b) Direct control of transport equipment (railroads / airplanes / ships / vehicles / vehicle instruments, etc.)
 - (c) Space equipment, submarine equipment
 - (d) Nuclear power control equipment, radiation related equipment
 - (e) Combustion equipment, electric heat equipment
 - (f) Disaster prevention and security equipment
 - (g) Elevating equipment
 - (h) Amusement facilities
 - (i) Facilities subject to government or industry regulations
 - (j) Use in applications that require a high degree of safety, any other equipment, instruments, or the like that could endanger life or human health

3. Warranty

- (1) The warranty period for Sunmulon products shall be 1 year after purchase or delivery to the specified location.
- (2) Warranty scope should a failure occur in Sunmulon product during the above warranty period for reasons attributable to Sunmulon, then Sunmulon shall provide that product, free of charge, the same quantity. Further, in no event shall liability of Sunmulon exceed the individual price of the product on which liability is asserted.
- (3) Failures caused by the following reasons shall be deemed outside the scope of this warranty.
 - (a) The product was handled or used deviating from conditions / environment listed in the catalogs
 - (b) The failure was caused by reasons other than Sunmulon product
 - (c) Modification or repair was performed by a party other than Sunmulon
 - (d) Replacement of maintenance parts, installation of accessories, or the like was not performed properly in accordance with the user's manual and catalogs
 - (e) The failure could not have been predicted with the scientific and technical standards at the time when the product was shipped from Sunmulon
 - (f) The failure was due to other causes not attributable to Sunmulon (including cases of force majeure such as natural disasters and other disasters)
- (4) The warranty listed in this Safety Precautions is the full and complete warranty for Sunmulon products, and Sunmulon shall bear no liability whatsoever regarding special damages, indirect damages, incidental damages, or passive damages that occurred due to Sunmulon product.

4. Handling precautions for switch

- (1) Do not perform wiring with power supplied to the switch. Do not touch the terminals or other charged parts of the switch while power is being supplied. Doing so may result in electric shock.
- (2) Be careful of electrostatic breakdown when handling.
- (3) Do not drop or otherwise apply strong force to the switch.
- (4) Do not place heavy objects on the switch.
- (5) Do not operate or use the housing (switch unit) by itself. Use the switch with assembled the illuminated part (LED module or button).
- (6) Pushbutton switches are designed to be operated by fingertips. Operating the switch using a sharp object (screwdrivers, tweezers, etc.), hard object (metal, etc.), or with a large or sudden force, may cause deform or damage the switch.
- (7) Do not use the switch under loads that exceed the rated switching capacity or other contact ratings. Doing so may result in welding of the contact, or burnout accidents.

Safety Precautions for All Illuminated Pushbutton Switches

(8) For inductive load, the arc by back EMF may cause contact failure. Insertion of arc prevention circuit as the following is recommended.

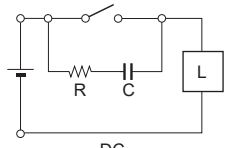
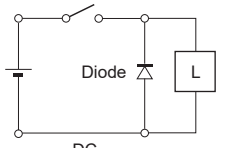
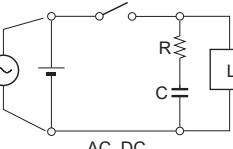
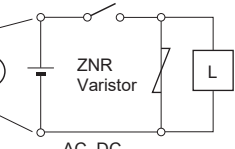
Circuit	Element selection	Circuit	Element selection
 <p>DC</p>	<p>C : 1 to 0.5 μF \times switch current (A) R : 0.5 to 1 Ω \times switch voltage (V)</p> <p>The values may change according to the characteristics of the load. Determine ideal capacitance and resistance values through testing.</p>	 <p>DC</p>	<p>The diode must withstand a peak inverse voltage 4 times higher than the power supply voltage and regarding a forward current must as high or higher than the load current.</p>
 <p>AC, DC</p>		 <p>AC, DC</p>	<p>Use a varistor that can withstand the power supply voltage sufficiently. (1.5 times or more)</p>

(9) Following circuits show examples of an anti-chattering circuit.

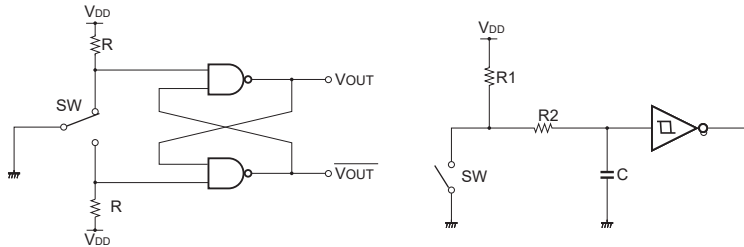

(10) Illumination

- (a) Do not apply a voltage between the LED terminal that is greater than the rated voltage. Doing so may damage the LED, cause lighting failure.
- (b) LEDs cannot be lit directly by AC circuit should be provided rectifier smoothing circuit for products other than AC input type.

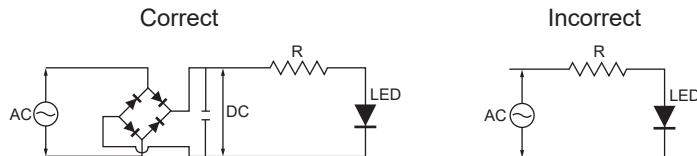

- (c) When wiring, pay attention to the polarity of the terminals.
- (d) Simultaneous lighting may not be possible with Dual-Color illumination or Split-Face illumination (2, 3, or 4 split illumination), check the catalog.
- (e) Apply voltage directly to LEDs of Non-built-in resistor type will damage the LEDs, so connect an appropriate external resistor.

(11) Wiring

- (a) Do not apply a soldering iron to the switch housing. Doing so may deform the terminals and cause defects.
- (b) See catalog for models compatible with flux prevention measures terminal. Be careful not to allow flux to penetrate sliding parts such as buttons. Use non-corrosive rosin solution as flux for dip soldering.
- (c) For soldering other than flux-preventive models, hand solder with the terminals facing down to prevent flux from penetrating into the switch.



- (d) The housing of KA, K2, and K9 series are designed for reflow soldering.
- (e) Use the appropriate wire size for the applied voltage and current, and solder properly. Use of the product with incomplete soldering may cause abnormal heat generation, resulting in a fire hazard.
- (f) After wiring is completed, maintain an appropriate insulation distance.

Safety Precautions for All Illuminated Pushbutton Switches

(12) Usage environment

- (a) Do not use in the presence of flammable or explosive gases such as gasoline, thinner, LPG, etc.
- (b) Avoid using the product in places where corrosive or silicon gas is generated, high temperature, high humidity, sea breeze or direct sunlight.
- (c) Provide appropriate protection when using the product in places where it is exposed to water, oil, metal powder, or dust.
- (d) Do not use the product in a place subject to vibration or shock. It may cause malfunction or damage.
- (e) When installed in a close grouping or continuously lit, the ambient temperature may exceed the specified value due to heat generation. Take measures such as ventilation and lowering the operating voltage.
- (f) When checking the actual equipment, load conditions and operating environment should be the same as the actual operating conditions.
- (g) The ambient temperature for storage is -25°C to 65°C (No freeze, no condensation).

(13) When wiping off dirt on the exterior of the switch and accessories such as side plates, wipe lightly with a soft, dry cloth. Organic solvents such as thinner, benzene, alcohol, or other acidic chemicals may cause deformation, discoloration, or malfunction.

(14) Store the product away from malignant gases, dust, high temperature and high humidity, and keep it in our packing condition.

(15) When removing the illuminated part (or button) from the alternate switch housing, switch state should be in a free state.

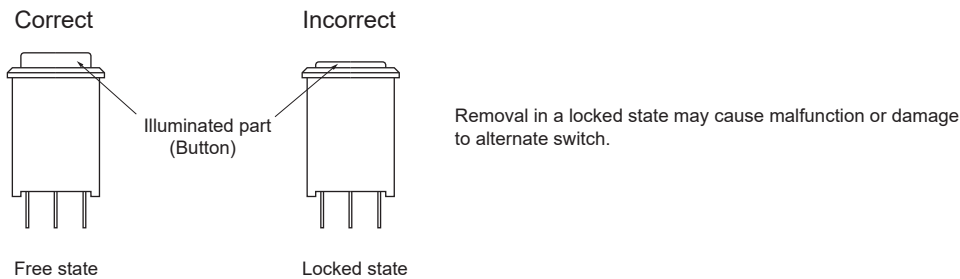

(16) Periodic inspection and replacement

- (a) Although mechanical and electrical durability are listed in the specifications column, deterioration of various parts (deterioration of resins and corrosion of metal parts) is possible due to the operating environment and method of use. We ask that you implement inspections for Sunmulon products to prevent accidents from occurring by conducting periodic inspections and replacements.
- (b) When the switch is left unused or stored for long periods, contact reliability may deteriorate due to oxidation of contacts, which may cause continuity failure, etc. Therefore, it is necessary to check the operation before use.

(17) Service scope

The price of Sunmulon products do not include the cost of services, such as dispatching technicians.