

Terminal cover unit: XH-4633

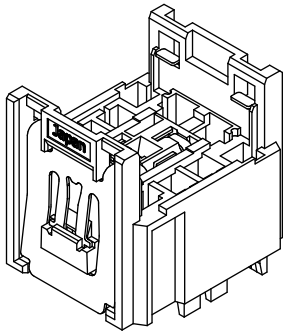

BOTTOM VIEW

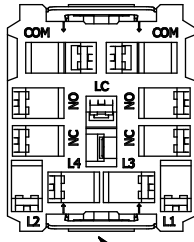

Sunmulon mark

Terminal crimping holder

(Single) PA-4634

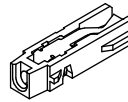

Applicable terminal
NC, NO
L1 ~ L4

(Double) PA-4635

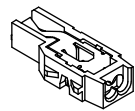

Applicable terminal
COM
LC

Assembling Procedure

1. Aim the clamp downwards and insert the wire vertically into the terminal crimping holder until hits completely the end of inside as shown below.
2. Press the terminal clamp with the inserted wire by using parallel pliers until fits inside the holder.

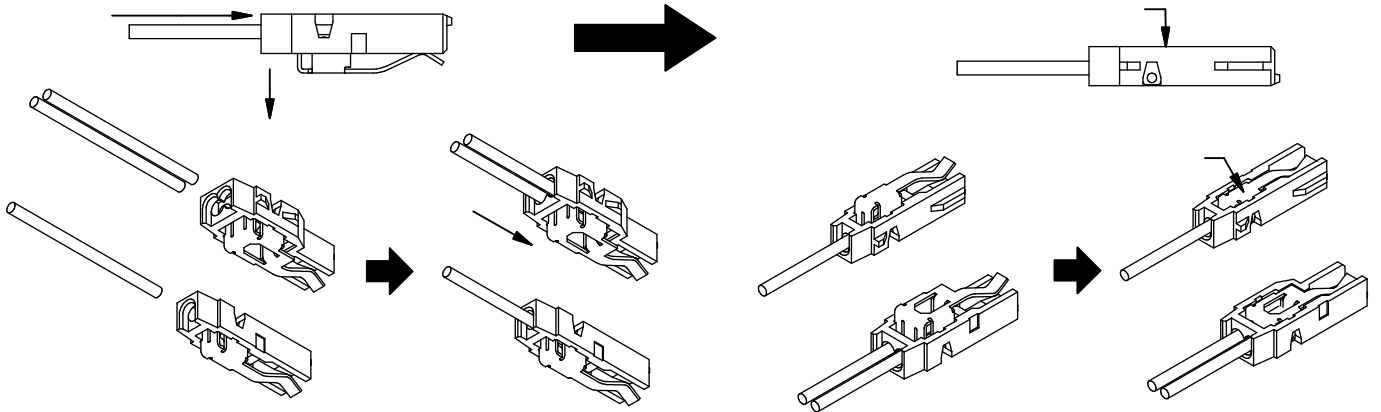

Standard applicable wire

UL1007, UL1430 AWG # 22, 20 (0.3 ~ 0.5sq) Outside diameter of the outer insulation 1.4 ~ 2.0

Recommend using parallel plier : MAUN No.BT13

When crimping, be careful not to apply force of more than 200N. Do not crimping again.

To remove terminal crimping holder, pull with spreading this tab outwards.

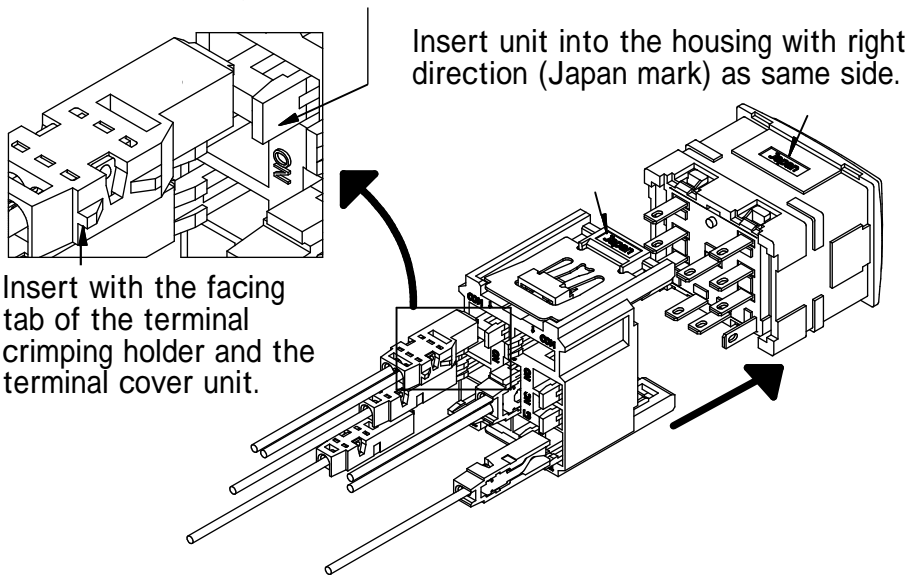

To remove terminal cover unit, pull while holding down the clamp on both sides.

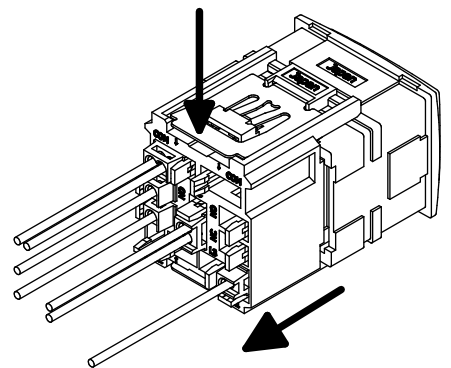

Insert with the facing tab of the terminal crimping holder and the terminal cover unit.

Insert unit into the housing with right direction (Japan mark) as same side.

- This unit is for XH series only. Other models cannot be used.
- Do not use the housing has already been soldered or deformed terminal.
- Placing vertical direction, more than 40 mm pitch is required.
- Do not use before the terminal crimping holder has been assembled.
- When applying current, do not insert or remove the terminal crimping holder.