

KC Lighted Pushbutton Switch

A printed-circuit mounted switch effective with very little current loaded featuring a soft design and a range of four button sizes.

Responsive tactile feedback offering two types, with and without a click-feel.

The rich lineup of options broadens the scope for designs.

• Button sizes

The provision of four types of button sizes (6 square type, 8 square type, 10 square type and 12 square type), it is possible to a sense of unity in panel designs.

• Depth behind panel

The overall length of switches is unified at 18mm. A short depth behind the panel of over 12mm.

• Illumination component

LEDs are used as the light-emitting devices to achieve full-face and dual color.

The soft illumination produces a high-quality feeling.

• Switch component

The use of a twin contact structure ensure high contact reliability.

Can be used from a minimum load of DC 1.5V, 10 μ A.

Two types are available, with and without a click-feel.

• Terminal

This is a product designed to prevent flux entry when mounting.

• Accessories

Cosmetic flanges are available for the 10 square type and 12 square type buttons, broadening the scope for designs.

• Design

A soft design with attention to fine details such as the rounded finish given to corners.

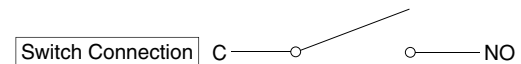

SPECIFICATIONS

Contact	Gold-Plated	
Electrical Rating	Maximum Load DC24V 50mA (Resistive)	Minimum Load DC1.5V 10 μ A (Resistive)
Insulation Resistance	More than 100M Ω at 500V DC	
Dielectric Strength	600V AC between NC and NO terminal	
	1000V AC between terminals and ground 50/60Hz for 60sec. at normal ambient temperature and humidity	
Contact Resistance	Less than 50m Ω (Initial) at DC6V 0.05A	
Electrical Life	more than 2,000,000 operations	
Mechanical Life	more than 2,000,000 operations	
Ambient Temperature	-15°C to +50°C	
Ambient Humidity	80% RH (max.)	

OPERATING CHARACTERISTICS

Operating Force (max.)	2.5N	Total Travel (max.)	2.5
------------------------	------	---------------------	-----

STRUCTURE

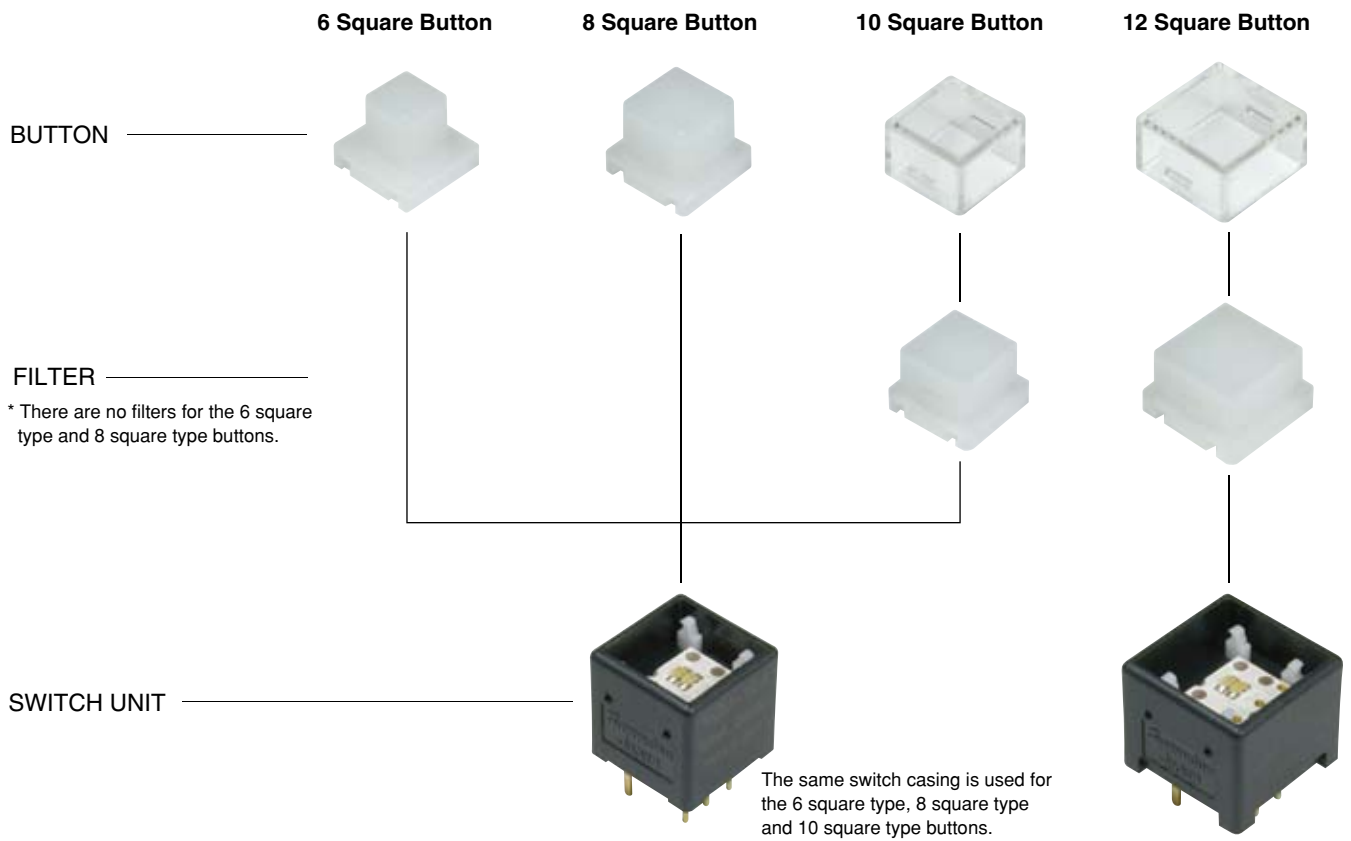

DIMENSIONS

PCB type	6 Square Button			<p>Top View</p>
	8 Square Button			<p>Top View</p>

Tolerance : ±0.4mm

DIMENSIONS

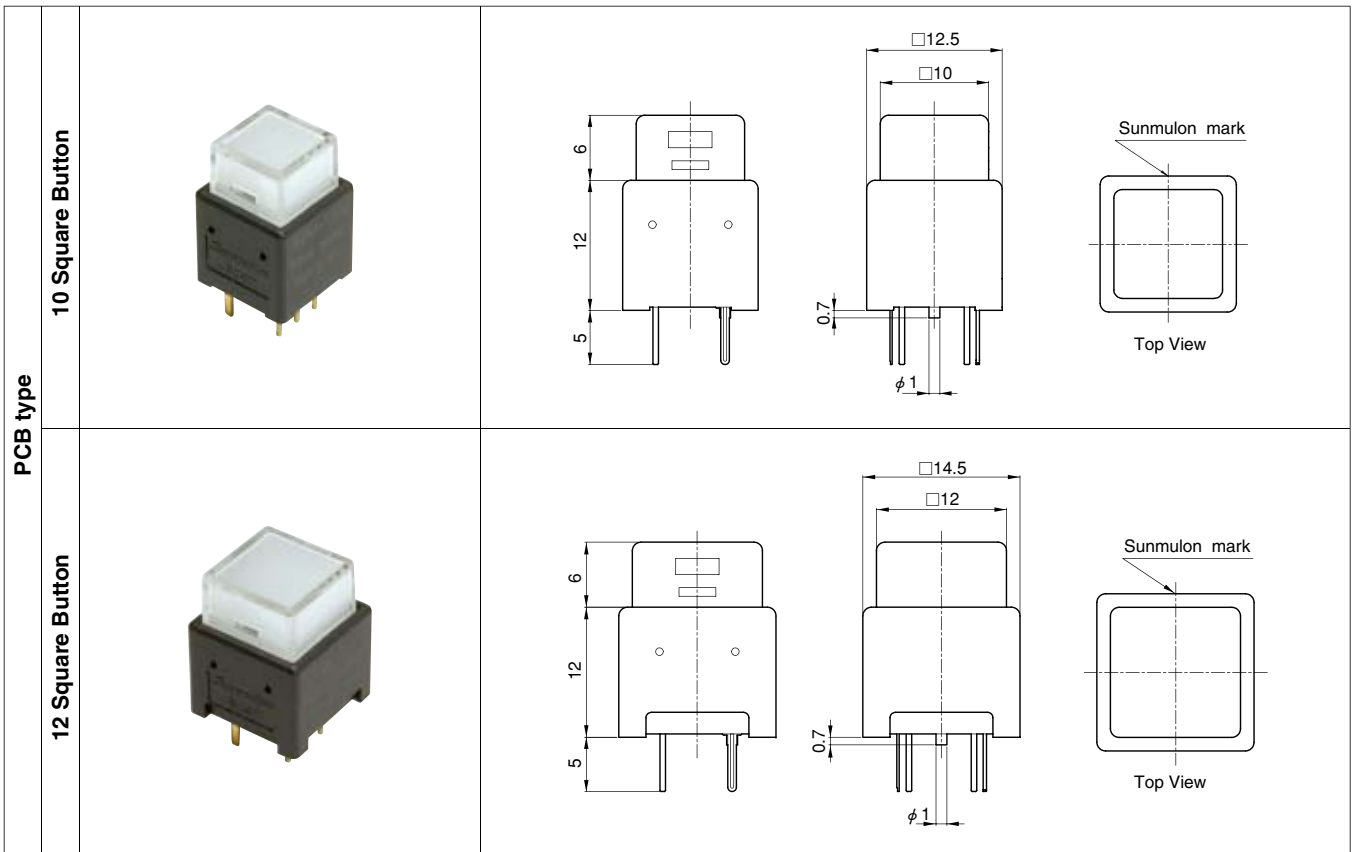

Tolerance : ±0.4mm

INTERNAL CONNECTION ARRANGEMENTS

● Full-Face

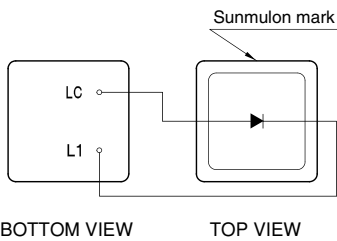

● Dual color common anode (common to each button)

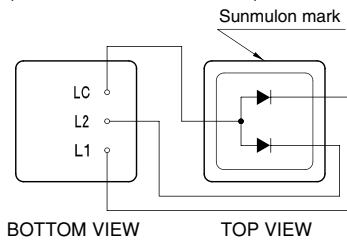

● Dual color common cathode (common to each button)

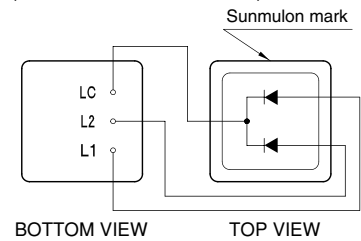

● Combination of dual-color LEDs

Terminals	LED Color					
LC-L1	Red	Green	Yellow	Super Blue	Super White	Super Green
LC-L2	Green	Yellow	Red	Super White	Super Green	Super Blue

TERMINALS

● TERMINALS LAYOUT (common to each button)

Mono-color light emitted

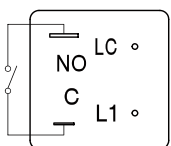

BOTTOM VIEW

Dual-color light emitted

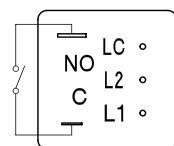

BOTTOM VIEW

No illumination

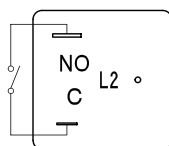

BOTTOM VIEW

● TERMINALS DIMENSIONS (common to each button)

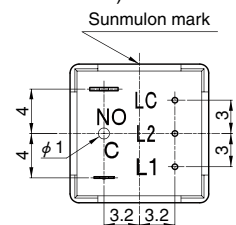

BOTTOM VIEW

TERMINAL SHAPE / PCB HOLE CUT-OUT

● TERMINAL SHAPE (common to each button)

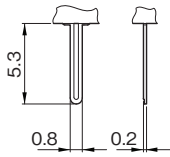

COM Terminal

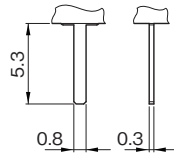

NO Terminal

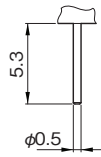

LC/L1/L2 Terminal

● PCB HOLE CUT-OUT (common to each button)

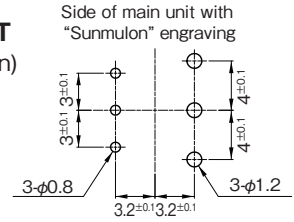

TOP VIEW

LED RATINGS

● LED RATINGS

(Ta=25°C)

ITEM	Color	Red	Green	Yellow	Super Blue	Super Green	Super White
	Max. operating current IFM (mA)		30	25	30	20	
DC reverse voltage VR (V)		5			5	5	3
Forward voltage VF (V) (Reference value)		2.0	2.1	2.0	2.9	2.9	3.0
Recommended operating current IF (mA)		20			10		
Pulse Lighting	Pulse Width PW (μS)	100			100	1000	
	Duty Ratio DR	10 ⁻¹			10 ⁻¹	1/20	
	Pulse allowable forward current IFP (mA)	100			50	48	

The value of the series resistor can be determined by the formula:

$$R = \frac{V_{CC} - V_F}{I_F}$$

V_{CC}: Supply Voltage

V_F: Forward Voltage

I_F: Recommended operating current

● Reference resistance (Ω)

Please determine resistance values with reference to the following when producing a uniform brightness for each color.

Color	Red	Green	Yellow	Super Blue	Super Green	Super White
5V	620	220	510	430	910	910
12V	2000	750	1800	2200	4700	4700
24V	4300	1600	3900	5100	11000	11000
Current value (mA) (reference values)	5	13	6	5	2	2

● Allowable forward current - ambient temperature

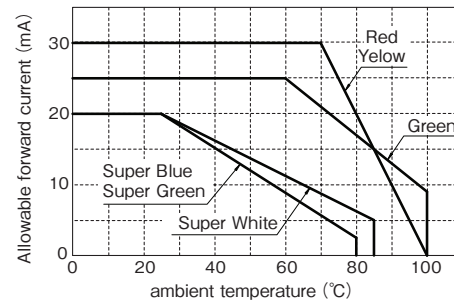

Panel Layout/Panel Cut Dimensions

● Cosmetic flanges

Panel thickness 1mm~3.2mm

	Panel Layout	Panel Cut Dimensions
10 square type cosmetic flange		
12 square type cosmetic flange		

* When an exterior finish, such as a coating, is applied to a panel, please ensure that the dimensions after applying the exterior finish are the same as the cut dimensions of the panel.

ACCESSORIES

Cosmetic flanges (for 10 square type and 12 square type only)

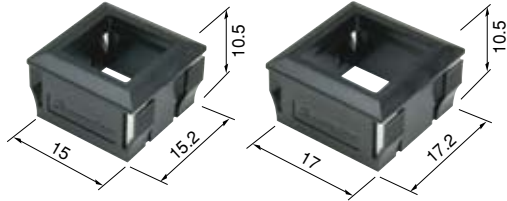

Button Size	Color	Part No.
10mm Square	Black	KC-4130-K
12mm Square	Black	KC-4140-K

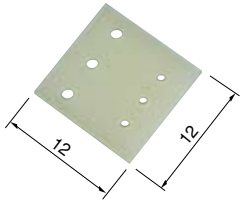

Spacer (common to each button)

The height from the circuit board to the panel can be adjusted in 1mm increments.

Part No.	KC-4144
----------	---------

ETCHING THE BUTTON / FILTER

We are able to etch the buttons and filters.
Please specify character font, size and color

FILTER DIMENSIONS

TOP VIEW

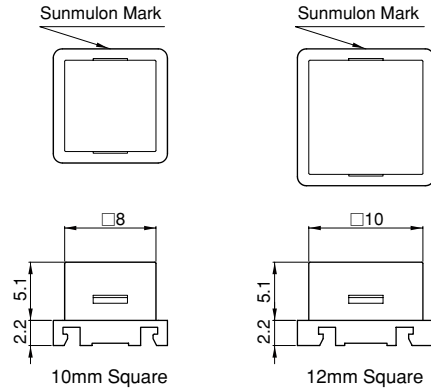

REPLACEMENT PARTS

●Button

Item \ Color	Red	Green	Yellow	Blue	Milk-White	Clear
6 Square Button	KC-4322-LR	KC-4322-LG	KC-4322-LY	KC-4322-LB	KC-4322-LM	
8 Square Button	KC-4323-LR	KC-4323-LG	KC-4323-LY	KC-4323-LB	KC-4323-LM	
10 Square Button	KC-4131-LR	KC-4131-LG	KC-4131-LY	KC-4131-LB	KC-4131-LM	KC-4131-CC
12 Square Button	KC-4141-LR	KC-4141-LG	KC-4141-LY	KC-4141-LB	KC-4141-LM	KC-4141-CC

●Filter

Item \ Color	Red	Green	Yellow	Blue	Milk-White
10 Square Button	KC-4132-LR	KC-4132-LG	KC-4132-LY	KC-4132-LB	KC-4132-LM
12 Square Button	KC-4142-LR	KC-4142-LG	KC-4142-LY	KC-4142-LB	KC-4142-LM

ASSEMBLY & DISASSEMBLY

1. Standard mounting dimensions for cosmetic flange (for 10 square type and 12 square type only)

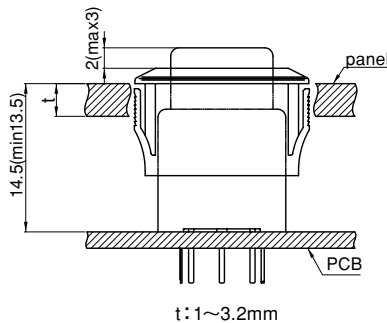

2. Fitting Button and Filter

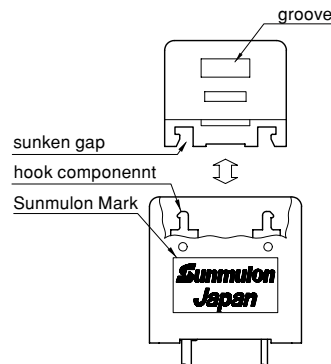

Please align and fit in place the protruding hook component with the sunken gap as shown in the above diagram.

To remove the button or filter, use the hooks of the extracting tool (type: SJ-0001) to clasp the indentations at both ends of the button and then pull out.

3. Removing Button and Filter

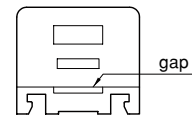

To detach the button and filter, insert the end of a flat object, such as a flat-tip screwdriver, into the gap shown in the above diagram.

ORDERING CODE I (Illumination Type)

KC □ - 06 □ 1 2 □ KN × C □
 KC □ - 08 □ 1 2 □ KN × C □
 KC □ - 10 □ 1 2 □ KN □ C □
 KC □ - 12 □ 1 2 □ KN □ C □

●CIRCUIT CHARACTERISTIC AND OPERATIONAL FEEL

M	With momentary click-feel
S	Without momentary click-feel

●BUTTON SIZE

06	6 Square	※1)
08	8 Square	※1)
10	10 Square	※2)
12	12 Square	※2)

●BUTTON SHAPE AND ILLUMINATION TYPE

S0	Square, full-face
S3	Square, dual color

●LED COLOR

7	Red	Full-Face : Put color No. into the frame 1
8	Green	
9	Yellow	Combination: 78, 89, 97,
14	Super Blue	714, 716, 718, 914, 916, 918,
16	Super White	1416, 1618, 1814
18	Super Green	

●LED CIRCUIT

D	Full-face
A	Dual color common anode
K	Dual color common cathode

●TERMINAL

C	Print Circuit
---	---------------

●HOUSING COLOR

KN	Black-without Flange
----	----------------------

●BUTTON COLOR

R	Red
G	Green
Y	Yellow
M	Milk-White
B	Blue
C	Clear
X	Without Button

●FILTER COLOR

1	Red
2	Green
3	Yellow
4	Milk-White
6	Blue
X	Without Filter

- ★ Button, filter and LED are in orange-yellow.
- ◆ For 10 square and 12 square types only.

Notes

- ※1) For the 6 square and 8 square types
- As transparent buttons are not available, please ensure that a code other than C (transparent) is selected as the button color code.
- As no filters are available, please ensure that X (no filter) is selected as the filter color code.
- If you wish to use dual color, please select M as the button color code.
- If you wish to use the switch without a button, please select 10 square type as the button size, since button sizes 6, 8 and 10 all use the same switch casing.

Example: KC□-10□□ X KN X C □

※2) For the 10 and 12 square types

- If you wish to use dual color, please select either C (transparent) or M (milk white) as the button color and 4 (milk white) as the filter color.
- If you wish to combine color buttons with color filters, please use either the same color for both, or use milk white for one of them.
- Example: R (red) / 1 (red) M (milk white) / 3 (yellow)
- The structure does not allow for the use of only a button without a filter (□/X).

ORDERING CODE II (No Illumination Type)

KC □ - 06 S0 × □ KN × C ×
 KC □ - 08 S0 × □ KN × C ×
 KC □ - 10 S0 × □ KN □ C ×
 KC □ - 12 S0 × □ KN □ C ×

●CIRCUIT CHARACTERISTIC AND OPERATIONAL FEEL

M	With momentary click-feel
S	Without momentary click-feel

●BUTTON SIZE

06	6 Square	※1)
08	8 Square	※1)
10	10 Square	※2)
12	12 Square	※2)

●BUTTON SHAPE AND ILLUMINATION TYPE

S0	Square, full-face
----	-------------------

●LED COLOR

X	Without LED
---	-------------

Notes

- ※1) For the 6 square and 8 square types
- As transparent buttons are not available, please ensure that a code other than C (transparent) is selected as the button color code.
- As no filters are available, please ensure that X (no filter) is selected as the filter color code.
- If you wish to use the switch without a button, please select 10 square type as the button size, since button sizes 6, 8 and 10 all use the same switch casing.

Example: KC□-10□□ X KN X C □

※2) For the 10 and 12 square types

- If you wish to combine color buttons with color filters, please use either the same color for both, or use milk white for one of them.
- Example: R (red) / 1 (red) M (milk white) / 3 (yellow)
- The structure does not allow for the use of only a button without a filter (□/X).

●LED CIRCUIT

X	Without LED
---	-------------

●TERMINAL

C	Print Circuit
---	---------------

●HOUSING COLOR

KN	Black-without Flange
----	----------------------

●BUTTON COLOR

R	Red
G	Green
Y	Yellow
M	Milk-White
B	Blue
C	Clear
X	Without Button

●FILTER COLOR

1	Red
2	Green
3	Yellow
4	Milk-White
6	Blue
X	Without Filter

- ★ Button, filter and LED are in orange-yellow.
- ◆ For 10 square and 12 square types only.

PRECAUTIONS

1. Please perform terminal soldering at 350°C within 3 seconds.
2. Do not move the terminal area during soldering or for 1 minute afterwards.
3. Character films are not included. When using a character film, please use a heat resistant film with a thickness of 0.1mm. For the dimensions, please refer to the table on the right.
4. Protective resistance is not built-in to the LEDs. Also note that the LEDs cannot be replaced.

●Character Film Dimensions

