

## VD LCD DISPLAY PUSHBUTTON SWITCH

Clear LCD (Message) and Reliable Pushbutton Switch (Operation) combined.

### FEATURES

- Wide view angle available with 33 X 64 dots (2,112dots) FSTN LCD, which can display maximum 12 characters (alphabets) X 4 column and graphics.
- Mono-Color(Red, Green, Orange Yellow, Super Blue, Super Green) , Dual-Color(Red/Green), Multiple-Color (RGB) back lighting LED provided.
- Negative display mode (Characters come out) gives good visibility.
- The switch has cross bar contacts which assures excellent reliability specially for dry circuit.

### Applications

- Broadcasting System ( Video, Voice, Sound )
- Ticket Publishing System ( Ticket Selling Machine )
- Surveillance, Control System(Fire Prevention, Building Maintenance, Traffic)
- Communication System ( Telephone Exchange, Rader, Satelite )
- Medical Electronics System ( Diagnosis, Data Process )
- Distribution System ( Automatic Warehouse, Filing System )
- Factory Automation System ( Product Line Surveillance, Robot )
- Financial System ( Dealing System, Automated Teller Machine )
- Public Equipment ( Educational Instrument )
- Measureing Instrument
- Other equipments.





## SPECIFICATIONS

Switch	Contact Material	PGS (Platinum, Gold, Silver) Cross Bar Contact	Contact Resistance	Less than 50mΩ(Initial) at DC6V 1A
	Contact Rating	AC125V 0.1A, DC30V 0.1A (Resistive Load)	Withstand Shock (miss indicate)	More than 10G
	Insulation Resistance	More than 100MΩ at 500V DC	Withstand Vibration (miss indicate)	Double Amplitude 1mm, Vibration 10~55Hz at 2 hours
	Dielectric Strength	600V AC RMS between NC and NO terminal 1500V AC RMS between terminals and ground 50/60Hz for 60sec. At normal ambient temperature and humidity	Mechanical Life	Momentary Action : more then 1,000,000 operations Alternate Action : more than 200,000 operations
Electrical Life			More than 100,000 operations at max. rated load	
LCD	Display Type	FSTN (Fine Super Twisted Nematic) (Duty : 1/33, Bias : 1/5)	Dots Area	11.19mm×19.81mm
	Dots number	Column 33×Row 64 (2,112 dots)	Indication Data	Non-synchronous Latch Type
	Dot size	0.28mm×0.31mm	Indication Mode	Graphic Character
	Indication Characters	Figures/Alphabets Maximum 12×4 column (5×7 dots)	Display Mode	Negative Type All transparent type (with LED backlight)
Ambient Temperature		-15°C to +50°C		
Ambient Humidity		80% RH (max.)		
Storage Temperature		-25°C to +65°C		

## OPERATING CHARACTERISTICS

Operating Force (max.)	3.5N	Total Travel (max.)	3mm
------------------------	------	---------------------	-----

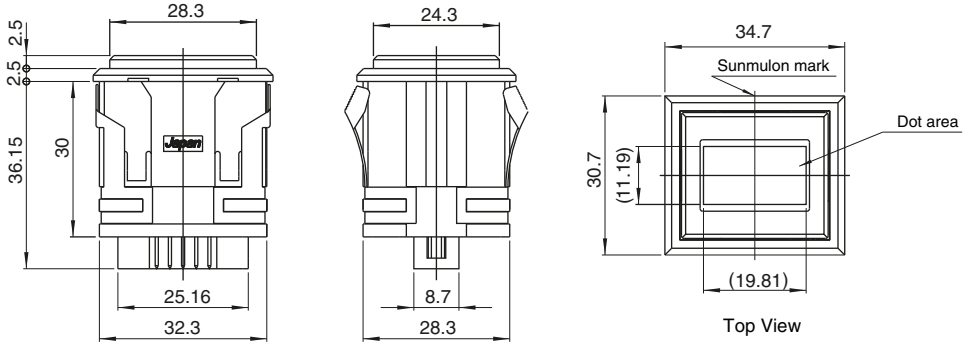
## DIMENSIONS

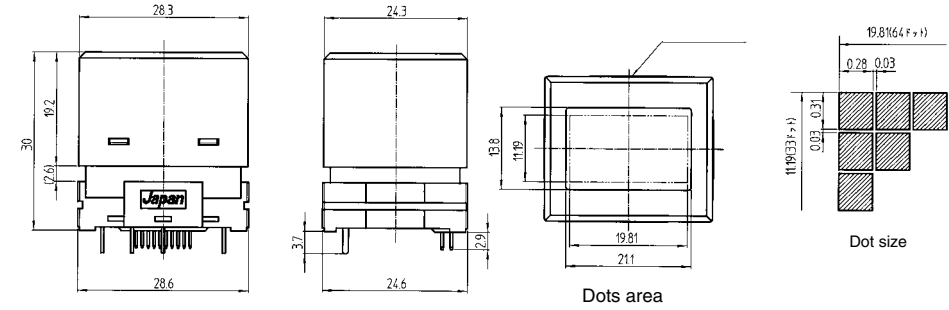
<p><b>Panel Mounting</b></p> 		
<p><b>PCB Mounting</b></p> 		

## Panel cut dimension / Terminal Layout (Panel Mounting Type)

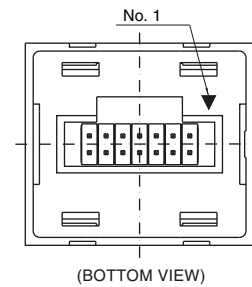
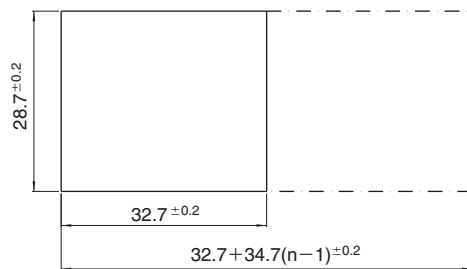

RECOMMENDED CONNECTER  
OMRON : XG4M-1430-U

\* Connecters are not appended, please procure above connector or prepare equivalent.

## TERMINAL SHAPE / PCB HOLE DIMENSION (PCB Type)

### ● TERMINAL SHAPE

### ● PCB Hole Dimension

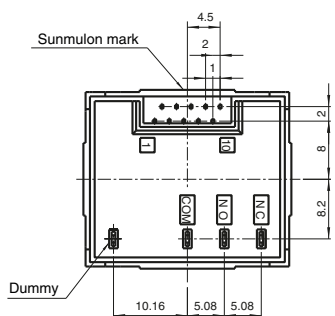

COM and NO terminals are excepted for Indicator type.  
(BOTTOM VIEW)

#### Switch Terminal

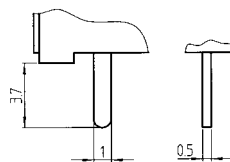

#### Connector Terminal

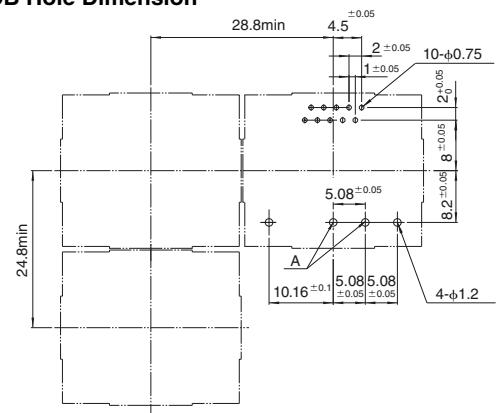
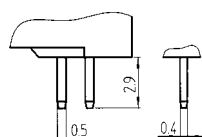

\* Hole A not needed for Indicator type.

(BOTTOM VIEW)

Tolerance : ±0.4mm

## ELECTRICAL & OPTICAL CHARACTERISTICS

Item	Symbol	Condition	MIN	TYP	MAX	UNIT
Supply Voltage	VDD	—	+4.5	+5	+5.5	V
High Level Input Voltage	V <sub>IH</sub>	—	0.8V <sub>DD</sub>	—	—	V
Low Level Input Voltage	V <sub>IL</sub>	—	—	—	0.2V <sub>DD</sub>	V
Driver IC Dynamic Current Consumption		at no access from MPU	—	—	130	μA
Viewing Direction		6 O'clock				
Viewing Angle	θ	T <sub>a</sub> 25°C	-50	—	60	deg
	φ	T <sub>a</sub> 25°C	-50	—	50	deg
Contrast Ratio	C.R.	T <sub>a</sub> 25°C	—	25	—	—
Response Time	t <sub>r</sub>	T <sub>a</sub> 25°C	—	100	200	mS
	t <sub>f</sub>	T <sub>a</sub> 25°C	—	150	300	mS

\* 1θ : Up & Down Direction

\* 2φ : Left & Right Direction

## INPUT & OUTPUT TERMINAL TABLE

Terminal No.		Symbol	Designation	Function
PCB Type	Panel Type			
1	1	VDD	Plus Voltage	⊕ Supply Input Terminal(+5V)
2	2	GND	Ground	⊖ Supply Terminal, All Signal Basic Electrical Potential
3	3	DATA	Data	Serial Data Signal
4	4	CLOCK	Clock	Serial Clogk Signal
5	5	COMMAND/DATA	Mode Exchange	Serial of Display Data Signal
6	6	SELECT	Select	Chip Select Signal
7	7	LC	LED(+)	LED Anode(+)
8	8	L1	LED 1	LED1 Cathode(-)
9	9	L2	LED 2	LED2 Cathode(-)
10	10	L3	LED 3	LED3 Cathode(-)
NC	11	NC	—	Switch NC
NO	12	NO	—	Switch NO
COM	13	COM	—	Switch COM
—	14	COM	—	Switch COM

## INTERNAL CIRCUIT

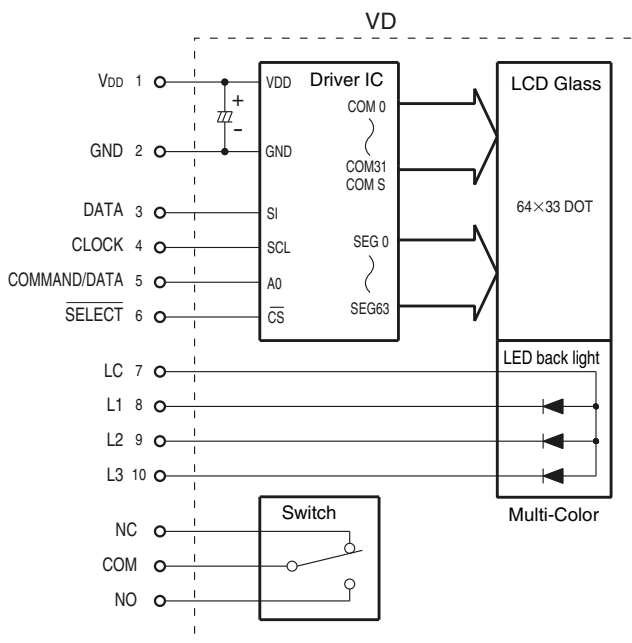

## TIMING CHARACTERISTICS

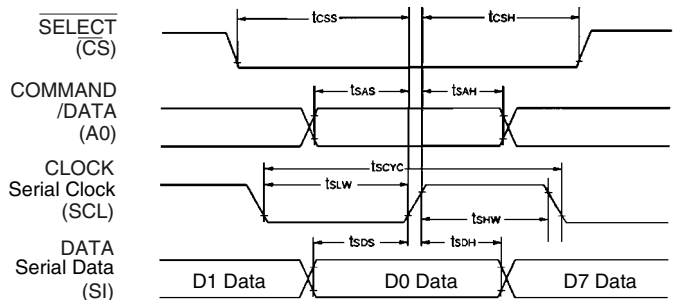

(V<sub>SS</sub>=0V, V<sub>DD</sub>=5.0V±10%, T<sub>a</sub>=-40~85°C)

Item	Signal	Mark	Min.	Max.	Unit
Serial Clock Cycle	Serial Clock	t <sub>SCYC</sub>	500		ns
Serial Clock "H" pulse width		t <sub>SHW</sub>	150		ns
Serial Clock "L" pulse width		t <sub>SLW</sub>	150		ns
Address Set Up Time	A0	t <sub>SAS</sub>	120		ns
Address Hold Time		t <sub>SAH</sub>	200		ns
Data Set Up Time	Serial Data	t <sub>S<sub>DS</sub></sub>	120		ns
Data Hold Time		t <sub>S<sub>DH</sub></sub>	120		ns
Serial Clock Time	CS1	t <sub>CSS</sub>	80		ns
		t <sub>C<sub>SH</sub></sub>	400		ns

\*1 Set up time for signal input to be provided less than 15ns.

\*2 All of Timing to be provided 20% and 80% of V<sub>DD</sub>.

## CONNECTION ARRANGEMENTS FOR BACK LIGHT LED

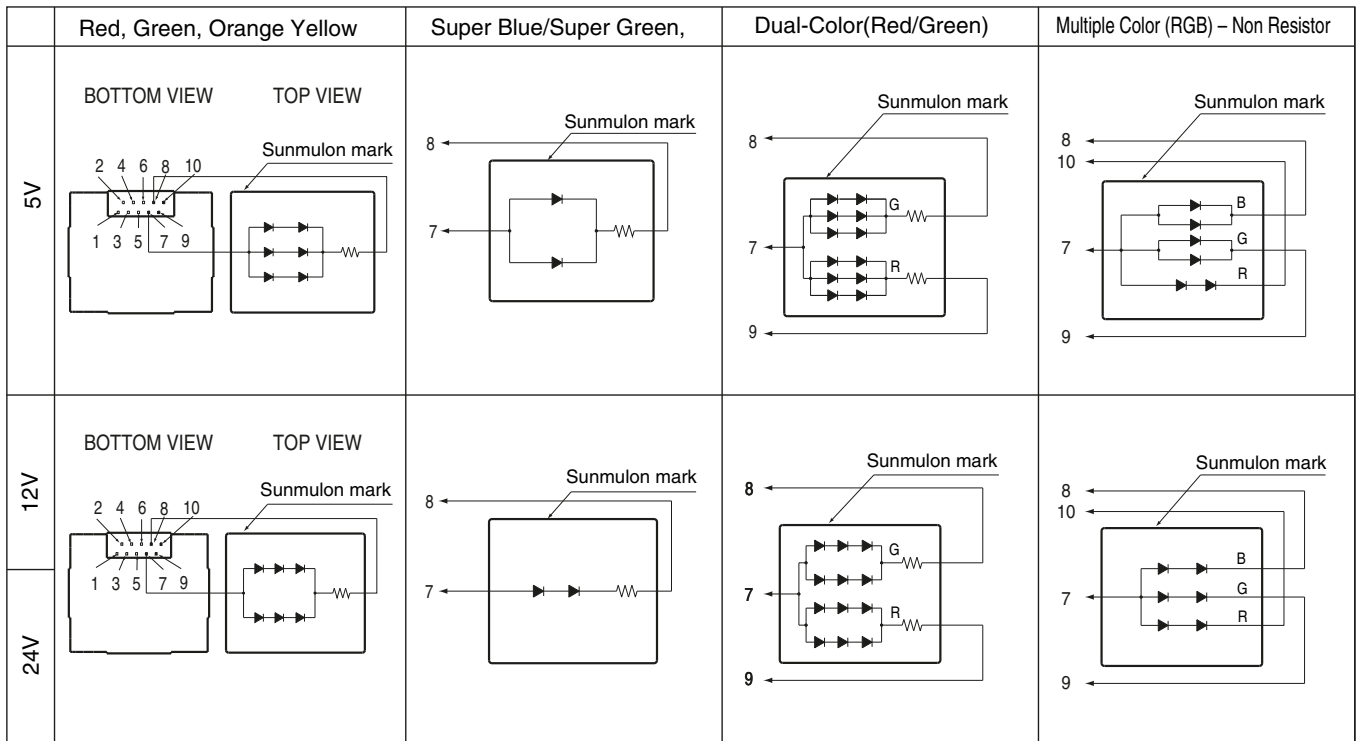

## BACK LIGHT LED DATA

R=Red G=Green OY=Orange Yellow SB=Super Blue SG=Super Green

### ● BACK LIGHT LED DATA

DC Supply Voltage (V)	Current Rating (mA)					
	Mono-Color					DUAL-COLOR
	R	G	OY	SB	SG	R G
5V (±5%)	21	36	36	26	26	21 36
12V·24V (±5%)	14	26	26	13	13	14 26

### ● EXTERNAL RESISTOR

Switches are normally fitted with internal resistors to operate on 5, 12, 24V DC supply. In case of non-resistor type, suitable external current limiting resistors must be installed as shown by the table and formula

Item	Mono-Color, Dual-Color						Mono-Color(Super)				Multi-Color					
	5V			12·24V			5V		12·24V		5V			12·24V		
	R	G	OY	R	G	OY	SB	SG	SB	SG	R	SB	SG	R	SB	SG
Max. operating current I <sub>FM</sub> (mA)	75	75	75	50	50	50	40	40	20	20	30	50	50	30	25	25
DC reverse voltage V <sub>R</sub> (V)	8	8	8	12	12	12	5	5	10	10	10	3	3	10	6	6
Forward voltage V <sub>F</sub> (V)	3.6	4.4	4	5.4	6.6	6	2.9	3.1	5.8	6.2	3.6	3.2	3.2	3.6	6.4	6.4
Recommended operating current I <sub>F</sub> (mA)	21	36	36	14	26	26	26	26	13	13	10	16.6	16.6	10	8.3	8.3
Wiring Diagram	Mono-Color (Fig.1) Dual-Color(Fig.2)						Fig.1				Fig.3					

Current Reduced Factor(Over 25°C working Temperature) : 0.33mA/°C (DC)

: 1.6mA/°C (PULSE)

Pulse Lighting

Pulse Width Pw = 100μS Duty Ratio Dr = 10<sup>-1</sup> I<sub>FM</sub>=100mA

### ● The value of the series resistor can be determined by the formula:

$$R = \frac{V_{cc} - V_F}{I_F}$$

V<sub>cc</sub>: Supply Voltage  
V<sub>F</sub>: Forward Voltage  
I<sub>F</sub>: Forward Current

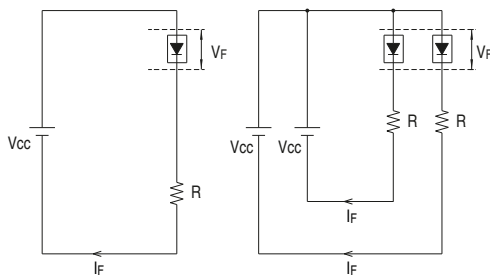
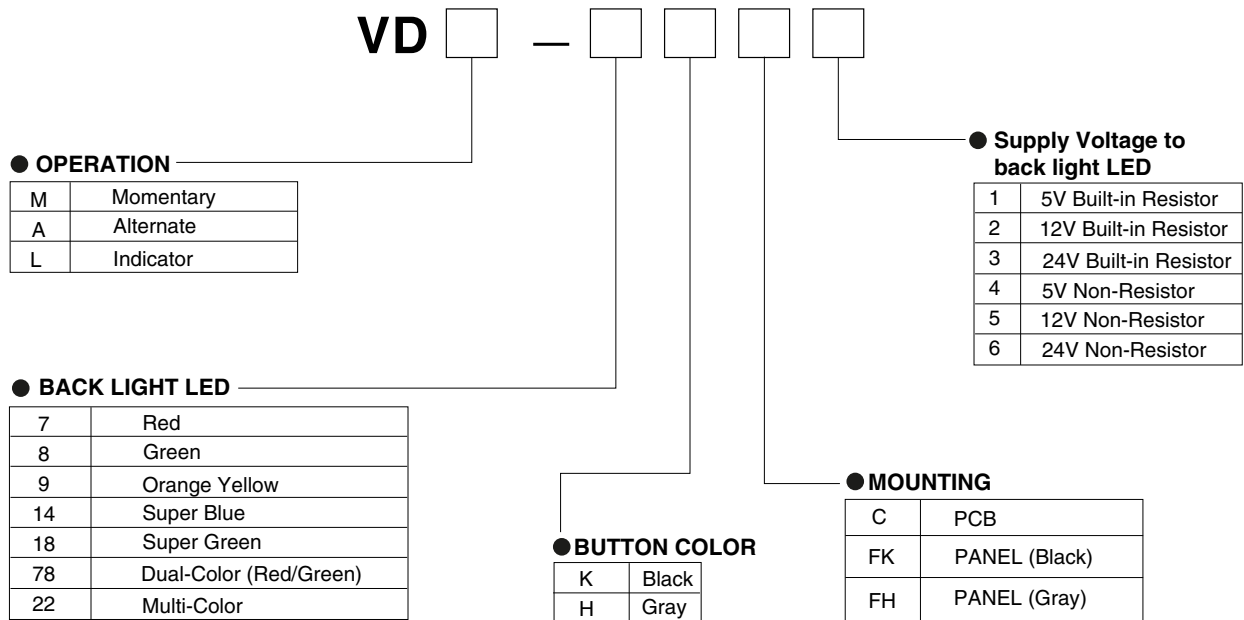

Fig. 1

Fig. 2

Fig. 3

ORDERING CODE



● NOTES

- 1) Regarding Dual-Color simultaneous illumination, please select 6 non resistor type and apply external resistor accordingly.
- 2) Regarding all Multi-Color type, please select non resistor type and apply external resistor accordingly.
- 3) Only 12V, 24V Built-in Resistor type and 12V,24V Multi-Color type can be controlled by VDC-2000.

CONTROL BOARD

● VDC-2004 (Control Board)

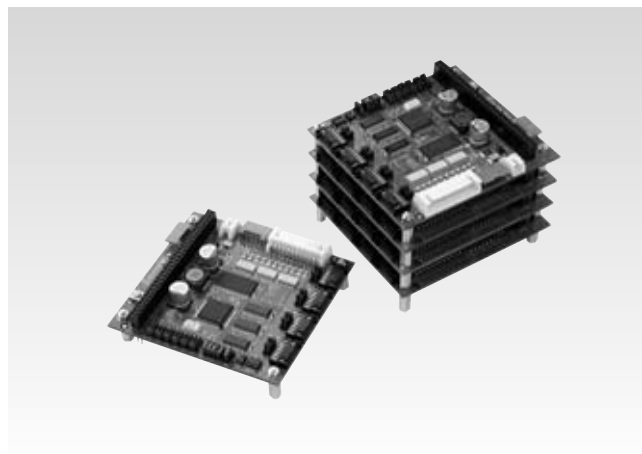

Regarding details of VDC-2004,VD BUILDER-II, please inquire us.